

TREK



2021 PROCALIBER CARBON

SERVICE MANUAL SUPPLEMENT

Table of Contents

Install the IsoSpeed	1
Install the rear derailleur hanger	3
Cable routings	3
Install the guards	4
Headset	4
Bottom Bracket	5

NOTE This manual has the unique design features and components for the 2021 Procaliber carbon bicycle.

Install the IsoSpeed

NOTE The PN for this kit is 525638. The kit contains all the hardware needed for the IsoSpeed assembly, except the rubber grommet (PN W599977) which is available separately.

1. With the frame in a proper repair stand, push down on the front of the frame to create a gap between the seat tube and the top tube.

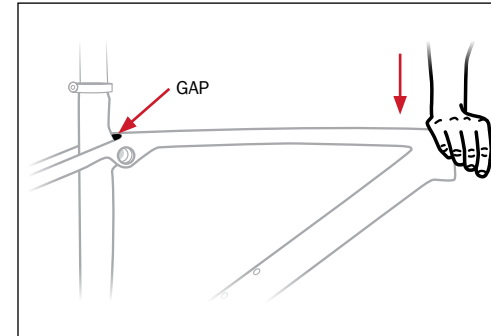

2. Insert the rubber grommet (PN: W599977) into this gap.

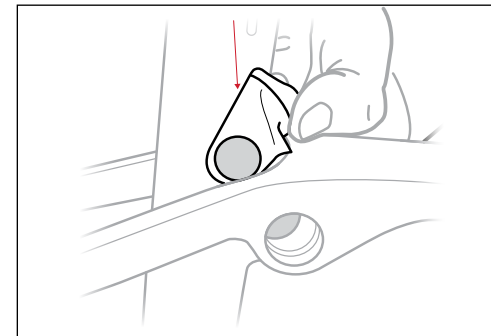

3. Make sure the grommet is in the proper position, and aligned with the bearing bores.

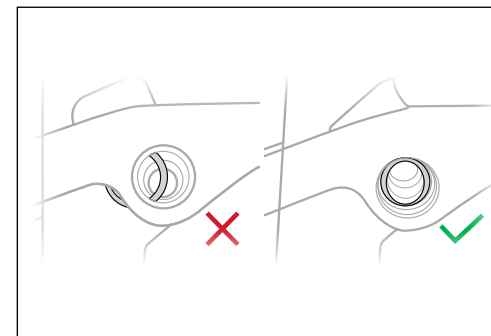

4. On the non-drive side, grease the bearing bore, then install the spacer and bearing.

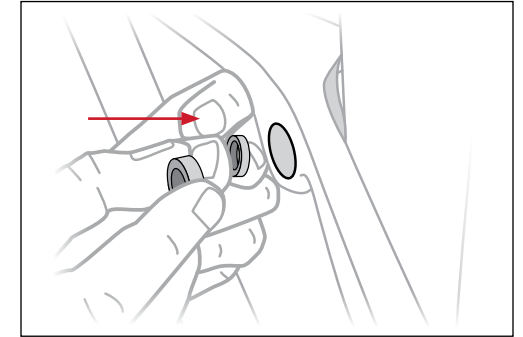

5. Use a bearing press to fully install the non-drive side bearing.

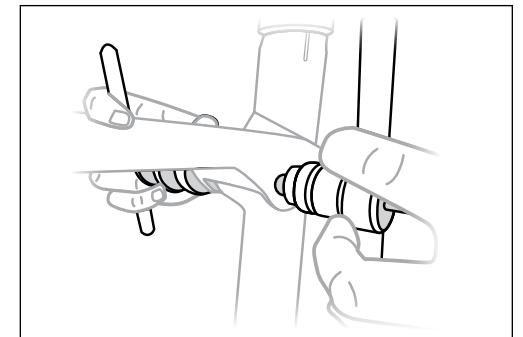

6. Install the IsoSpeed sleeve from the drive side.

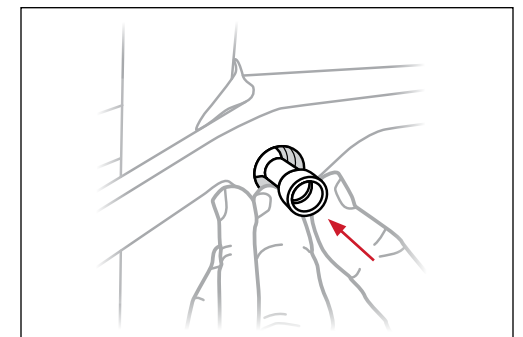

- 7.** Install the first IsoSpeed bolt in the non-drive side. Use your finger to push the sleeve towards the bolt to begin threading.

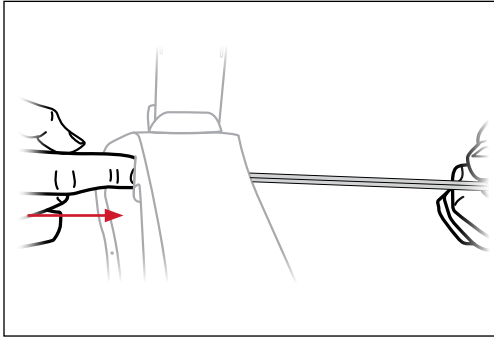

NOTE Do not thread more than two revolutions at this time.

- 8.** Grease the driveside bearing bore.
- 9.** While pushing the bolt and the sleeve towards the drive side, install the second IsoSpeed bolt and bearing in the drive side. Thread the bolt and press the bearing into the sleeve from the drive side.
- 10.** Use two 5mm wrenches to tighten both bolts.

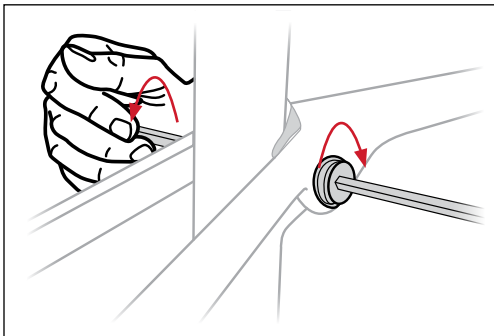

- 11.** Torque the bolts to 8Nm.

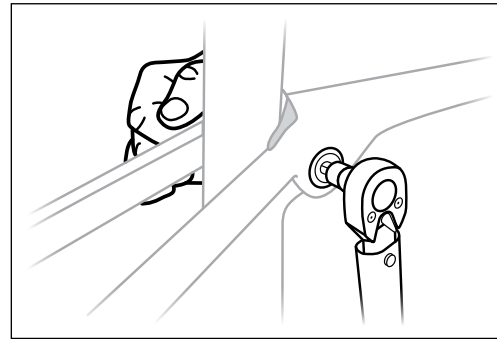

Install the rear derailleur hanger

CAUTION: Do not apply grease between the hanger and the bicycle frame.

CAUTION: Do not apply grease to the UDH bolt threads.

- 1.** Insert the hanger on the inside of the driveside chainstay and attach with the hanger bolt (left-hand thread).

NOTE Make sure to install the washer on the outer surface between the frame and the bolt.

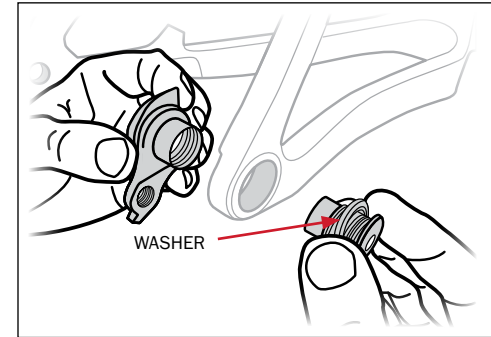

- 2.** Make sure to have the hanger in the correct position as shown.

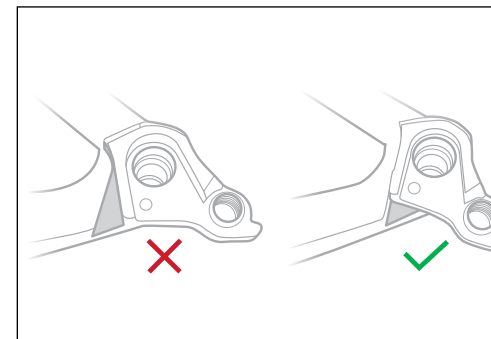

- 3.** Torque the hanger bolt to 25Nm (left-hand thread).

Cable routing

NOTE There are tubes inside the frame to guide the cable and hose routings from the head tube all the way through to the exit holes.

- 1.** Dropper post (optional)

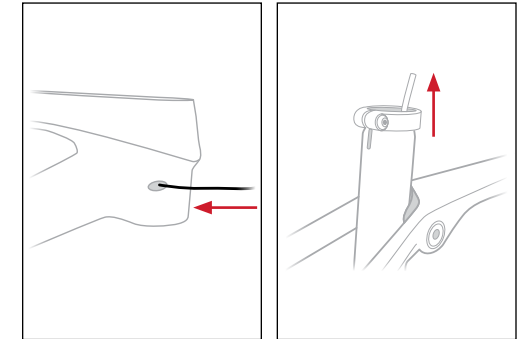

- 2.** Rear brake (upper hole in head tube)

- 3.** Rear derailleur (lower hole in head tube)

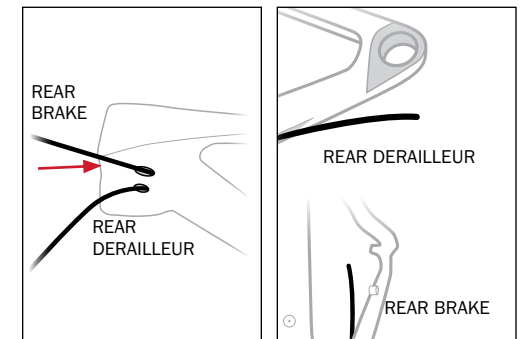

- 4.** If there is no dropper post, install the plug (PN W600649) in the head tube access hole.

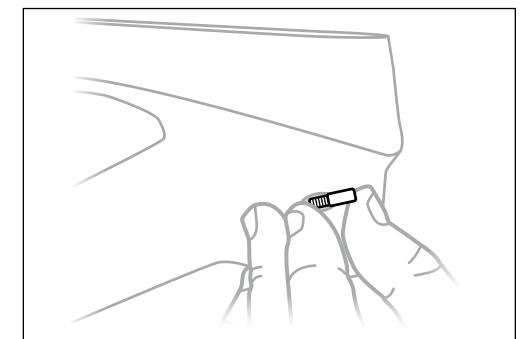

Install the guards

- Upper down tube PN: W582884
- Lower down tube PN: W599975
- Upper chainstay (includes a pin on the adhesive side for proper placement) PN: W582883
- Lower chainstay PN: W600295

1. Use isopropyl alcohol to clean the frame surfaces that mate with the guards.

⚠ CAUTION: Do not clean entire frame with isopropyl alcohol.

2. Remove the protective covering for the adhesive.

3. Attach the guards as shown.

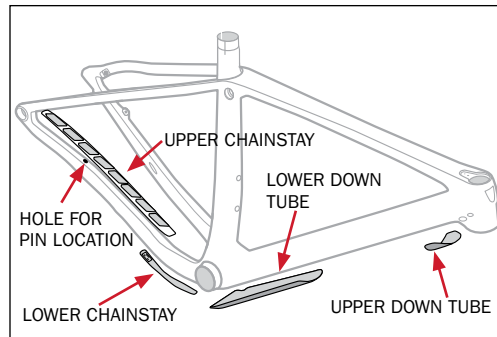

Headset

1. Install the crown, then the lower bearing on the steerer tube.
2. Install the fork from the bottom into the head tube.
3. On the steerer tube, install the upper bearing and the compression ring.

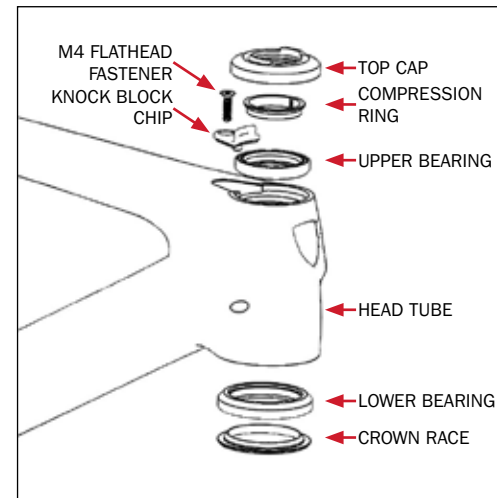

4. Use the M4 flathead fastener to install the Knock Block chip.

NOTE The 2021 Procaliber uses a new Knock Block assembly (PN 5252158). This is a 62-degree rotation system.

5. Install the top cap.
6. Install spacers as necessary.

Bottom Bracket

The 2021 Procaliber uses the BB92 pressfit standard bottom bracket.

Use your bottom bracket manufacturer's manual for removal and installation instructions.

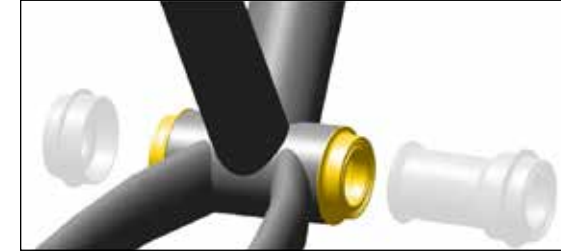

ILLUSTRATION: SRAM