



Quick Assembly Guide Full Suspension Bikes

TREK

! **IMPORTANT:** This assembly guide is not a replacement for the Trek Owner's Manual or other instructions required for your bicycle. The owner's manual comes in the box and can also be found at trekbikes.com/manuals.

▶ Watch the assembly video here:
trek.bike/build_a_bike > Full suspension bikes



⚠ **WARNING:** You add to the risk of injury if you use your bicycle in an incorrect manner. Misuse can add stress to the bike and cause wear on the frame or components. To decrease the risk of injury, you should use the bicycle in the manner for which it was designed.

This is gonna be awesome

Congrats on your new ride! Ready to build 'er up? Whether you're a first-time bike builder, an experienced torque-wrencher, or somewhere in between, this Assembly Guide will talk you through every step of the process.

Before you get started, take a look at the included parts section to make sure everything's there, give each step a quick read-through, and watch the assembly video. Then, roll up your sleeves, take a deep breath, and start with step one. You got this!

If you need a little extra support while you're building, we've got you covered. Just give us a call or visit your local Trek retailer. You'll be ready to hit the trails in no time.



Included

- 1 Preset torque wrench
- 2 Pedal wrench
- 3 Pedals (may not be included)
- 4 Bicycle owner's manual
- 5 1oz grease packet
- 6 Faceplate bolts and washers
- 7 Faceplate(s)
- 8 Shock pump (may not be included)

Not included



Air pump



Remove all packaging from the bike except the fork mount and tape holding the dropper post cable.

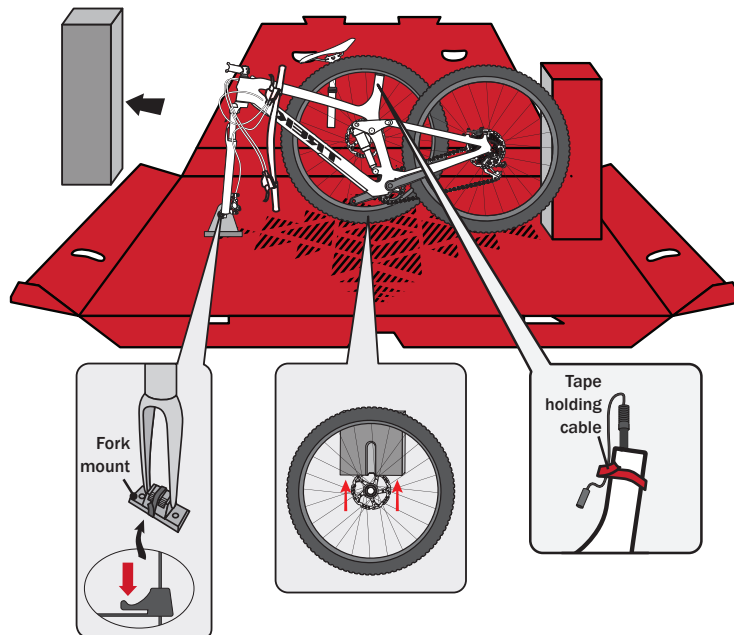

2

Check the bike for shipping damage and make sure all parts are included.

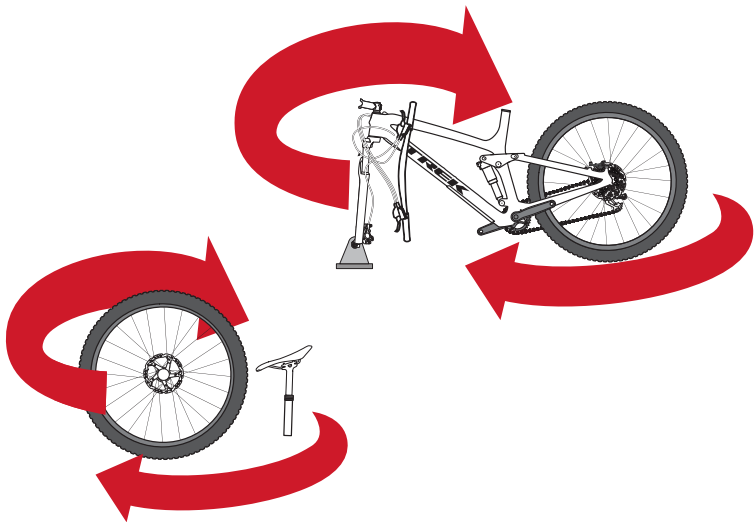
**3**

Install the handlebar.

1. Place the handlebar in the stem and attach the faceplate bolts, washers, and faceplate(s).
2. Tighten the faceplate bolts a few turns — do not fully tighten the bolts.

IMPORTANT: Make sure the cables are not pinched, twisted, or routed over the stem.

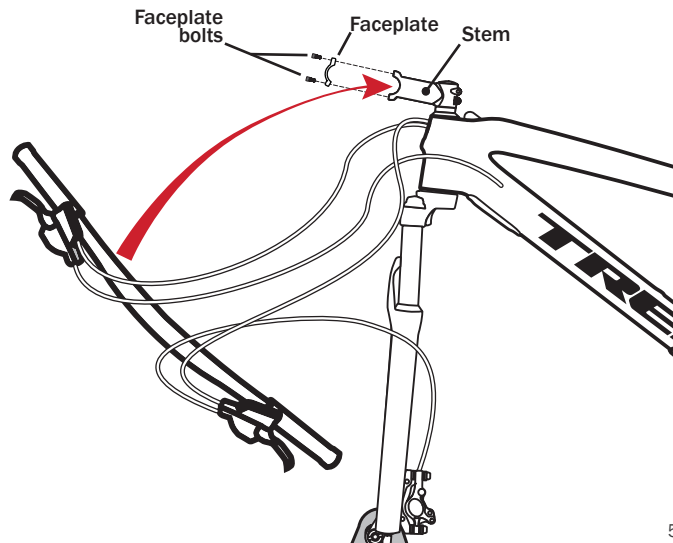

4

Tighten the faceplate bolts.

1. Using the guidemarks on the handlebar, center and adjust the angle of the handlebar.
2. Tighten the four bolts — a few turns at a time in an X-pattern — until you feel the tool click.

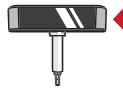

NOTE: If you have a two-bolt faceplate, alternate tightening between the top and bottom bolts.

IMPORTANT: Make sure the gap spacing (stem to faceplate) is equal with all four bolts.

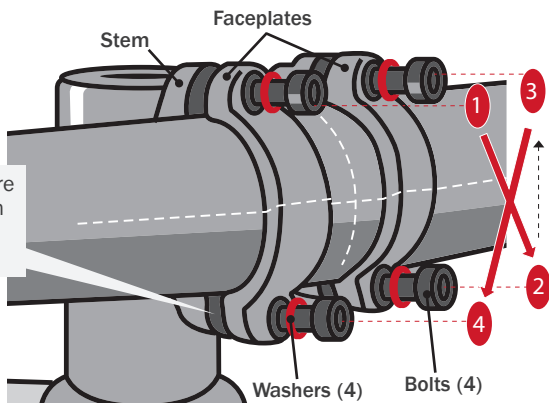
**5**

Remove the fork mount and pad spacer.

1. Turn the lever counterclockwise to disconnect the axle. Pull the axle out of the fork mount.
2. Remove the fork mount.
3. Remove the pad spacer from between the brake pads.

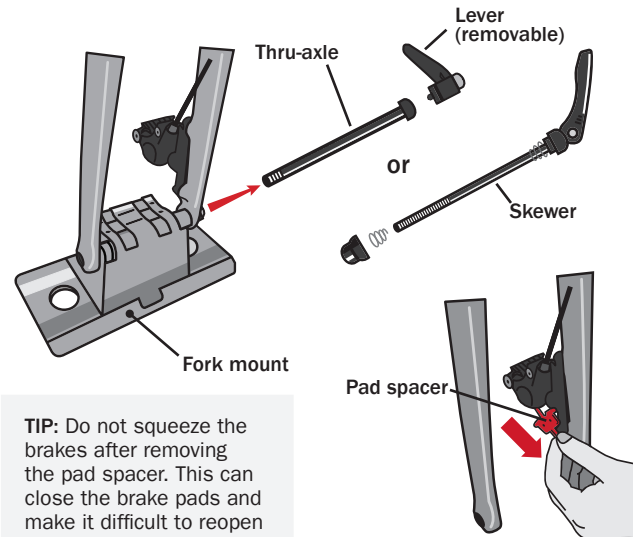

TIP: Do not squeeze the brakes after removing the pad spacer. This can close the brake pads and make it difficult to reopen them.

6

Insert the wheel into the fork and install the axle.

IMPORTANT: Make sure the axle is properly seated in the dropouts.

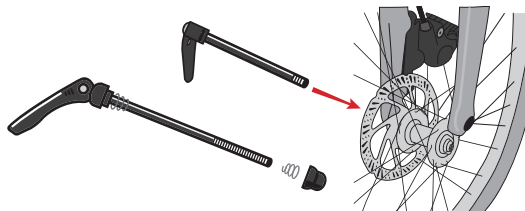

IMPORTANT: If you tightened hard enough, the lever should leave an imprint on your hand.

**7**

Inflate both tires.

1. Remove the dust cap.
2. Presta only — rotate the valve head counterclockwise to open it.
3. Inflate both tires to within the range listed on the tire.
4. Presta only — rotate the valve head clockwise to close it.
5. Put the dust cap back on the valve.

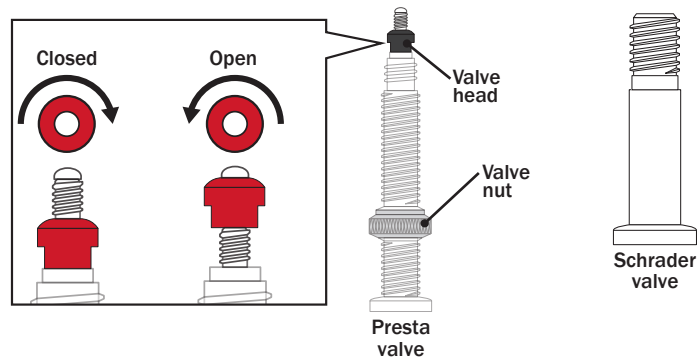
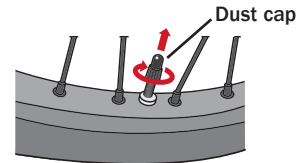

8

Loosely install the pedals.

1. Lubricate the pedal threads with 1-2 drops of the grease provided.
2. Hand tighten the pedals onto the crank arms. Make sure you tighten the nut and not the pedal itself.

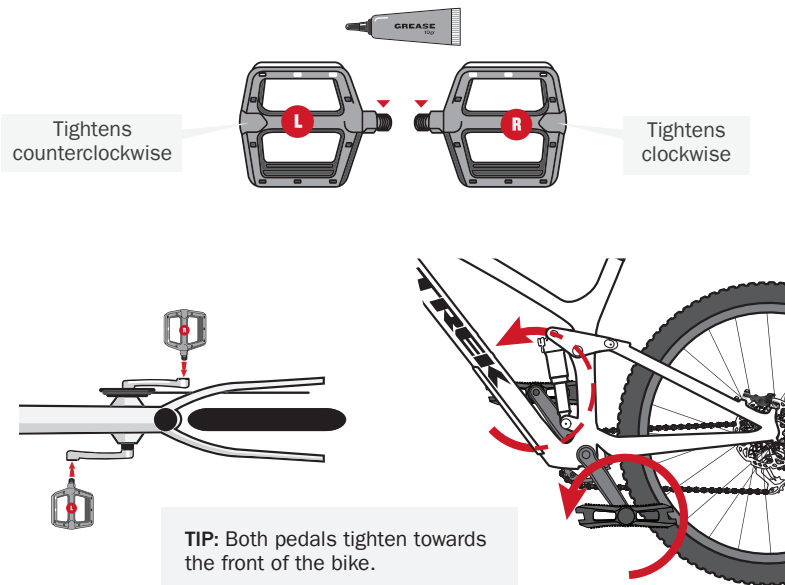
**9**

Fully tighten the pedals with the pedal wrench.

⚠ WARNING: The chainring has sharp points. Be careful when working around the chainring. Failure to do so may result in cut or pinched skin.

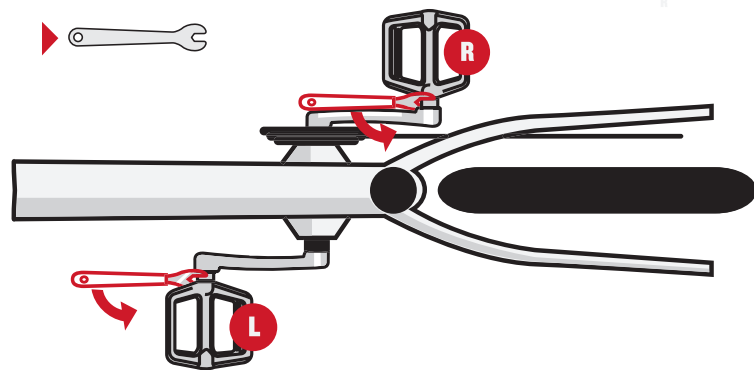

10

Install the dropper post (if necessary).

1. Attach the cable to the actuator and insert the housing into the actuator.
2. Insert the seatpost into the seat tube and tighten the seatpost clamp bolt until you feel the tool click.

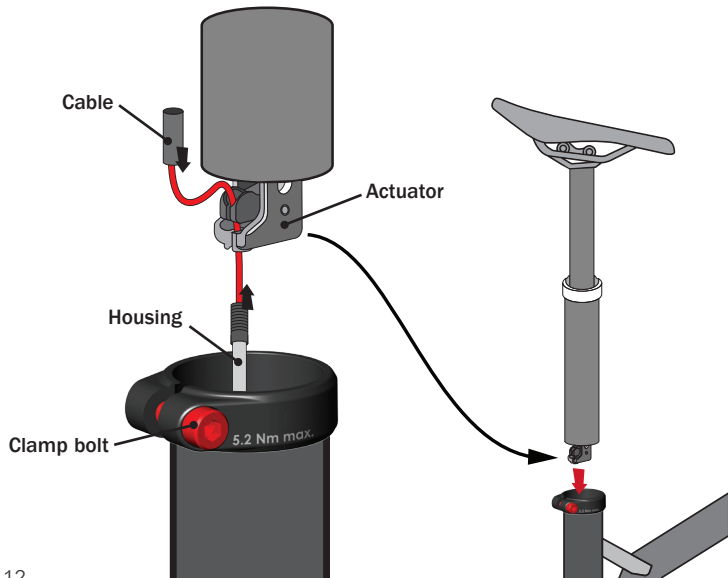

11

Install the seatpost (if necessary).

NOTICE: Do not use grease on carbon frames or seat tubes. Standard grease can damage carbon.

1. Insert the seatpost into the seat tube.
2. Align the seat with the top tube.
3. Use the torque wrench to tighten the seatpost collar until you feel the tool click.

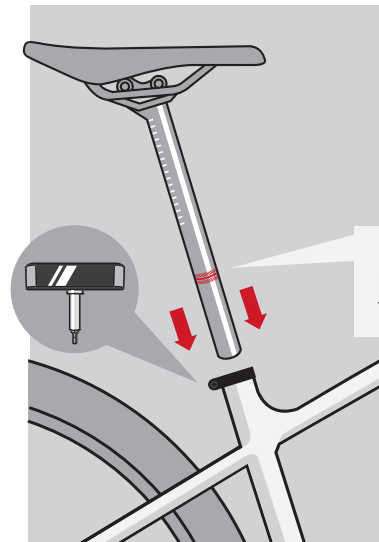

12

Adjust the seat height.

1. Put the bike next to a wall for support.
2. Sit on the seat to test the seat height. Your knee should be slightly bent when your foot is at the lowest position.
3. Adjust the height as necessary by raising or lowering the seatpost.
4. After determining your seatpost height, use the torque wrench to tighten the seatpost collar bolt until you feel the tool click.

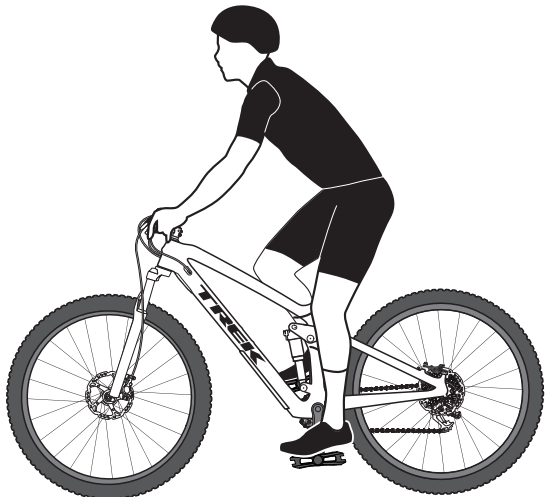
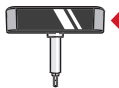

13

Set your suspension.

Mountain bikes require a small amount of set up for the individual rider. Follow the steps below to optimize your suspension performance.

1. Go to the on-line Suspension Calculator and determine your suggested suspension settings.



https://www.trekbikes.com/us/en_US/suspension-calculator/

2. Go to the video tutorial and apply the calculated suspension settings to your bike.



<https://www.youtube.com/watch?v=IZPOjp5vy64>

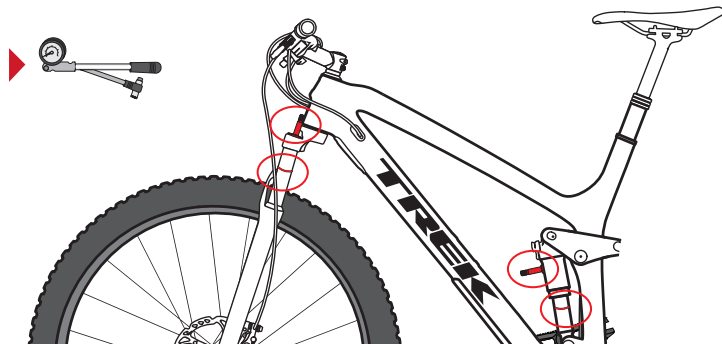

BICYCLE ASSEMBLY CHECKLIST

After you assemble your bike, complete this checklist:

- Handlebar and stem properly aligned? *(Step 4)*
- Faceplate bolts properly tightened? *(Step 5)*
- Pedals installed correctly and tightened? *(Steps 9-10)*
- Seat height correct and seatpost collar bolt tightened? *(Step 11 or 12)*
- Tires inflated to correct pressure? *(Step 8)*
- Register your bicycle?
- Perform a pre-ride check?



Register your bike at
[trekbikes.com/
ProductRegistration](https://trekbikes.com/ProductRegistration)



Watch the Pre-Ride
Check video at:
[youtube.com/user/
trebikesusa](https://youtube.com/user/trebikesusa)

**RIDE BIKES
HAVE FUN
FEEL GOOD**

For information about your bike's warranty, please see
trekbikes.com/inside_trek/warrantied_for_life



If you have questions, please contact your local Trek bike
shop, call Trek Customer Care at 800-585-8735 from
9am – 5:30pm Monday – Friday CST, or chat with us at
trekbikes.com/contactus



**CERTIFIED AWESOME
BY TREK**