



**Quick Assembly Guide**  
**City Bikes— No Suspension**

**TREK**

**!** **IMPORTANT:** This assembly guide is not a replacement for the Trek Owner's Manual or other instructions required for your bicycle. The owner's manual comes in the box and can also be found at [trekbikes.com/manuals](http://trekbikes.com/manuals).

**▶** Watch the assembly video here:  
[trek.bike/build\\_a\\_bike](http://trek.bike/build_a_bike) > City bikes



**⚠** **WARNING:** You add to the risk of injury if you use your bicycle in an incorrect manner. Misuse can add stress to the bike and cause wear on the frame or components. To decrease the risk of injury, you should use the bicycle in the manner for which it was designed.

## *This is gonna be awesome*

*Congrats on your new ride! Ready to build 'er up? Whether you're a first-time bike builder, an experienced torque-wrencher, or somewhere in between, this Assembly Guide will talk you through every step of the process.*

*Before you get started, take a look at the included parts section to make sure everything's there, give each step a quick read-through, and watch the assembly video. Then, roll up your sleeves, take a deep breath, and start with step one. You got this!*

*If you need a little extra support while you're building, we've got you covered. Just give us a call or visit your local Trek retailer. You'll be on the road in no time.*



## Included

- 1 Preset torque wrench
- 2 Pedal wrench
- 3 Pedals
- 4 Bicycle owner's manual
- 5 1oz grease packet
- 6 Faceplate bolts and washers
- 7 Faceplate(s)

## Not included



Air pump



Remove all packaging from the bike and slide the bike out of the box.

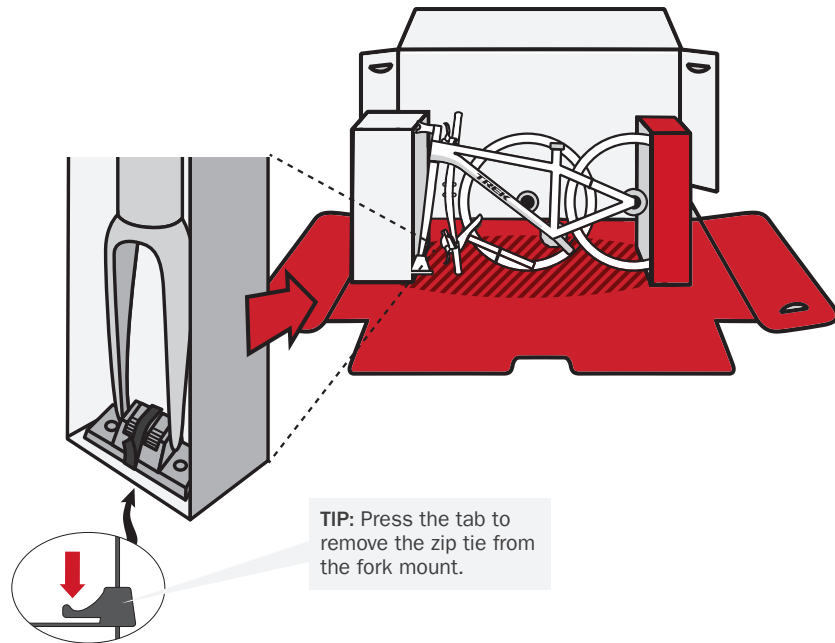

**2**

Check the bike for shipping damage and make sure all parts are included.

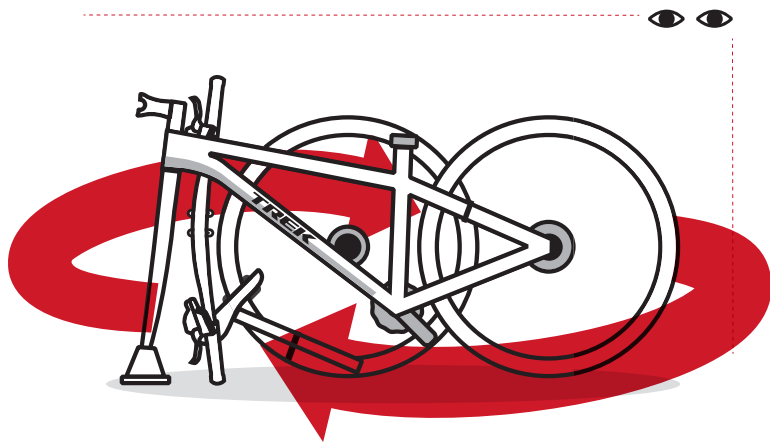
**3**

Install the handlebar.

1. Place the handlebar in the stem and attach the faceplate bolts, washers, and faceplate(s).
2. Tighten the faceplate bolts a few turns — do not fully tighten the bolts.

**IMPORTANT:** Make sure the cables are not pinched, twisted, or routed over the stem.

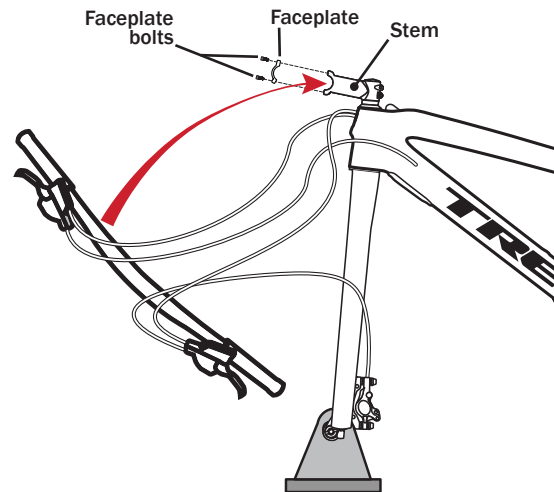

# 4

## Tighten the faceplate bolts.

1. Using the guidemarks on the handlebar, center and adjust the angle of the handlebar.
2. Tighten the four bolts — a few turns at a time in an X-pattern — until you feel the tool click.

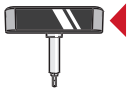

**NOTE:** If you have a two-bolt faceplate, alternate tightening between the top and bottom bolts.

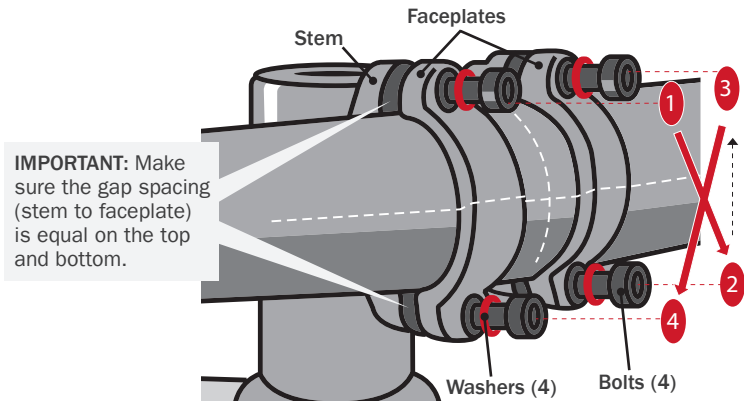

# 5

## Install the pedals.

1. Lubricate the pedal threads with 1-2 drops of the grease provided.
2. Hand tighten the pedals onto the crank arms. Make sure you tighten the nut and not the pedal itself.
  - Right pedal (R) — tightens clockwise
  - Left pedal (L) — tightens counterclockwise

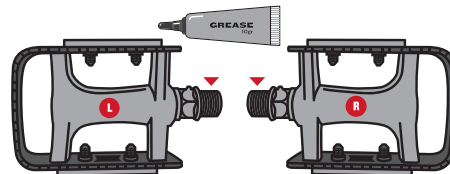

**⚠ WARNING:** The chainring has sharp points. Be careful when working around the chainring. Failure to do so may result in cut or pinched skin.

**6**

Fully tighten the pedals with the pedal wrench.

**TIP:** Both pedals tighten towards the front of the bike.

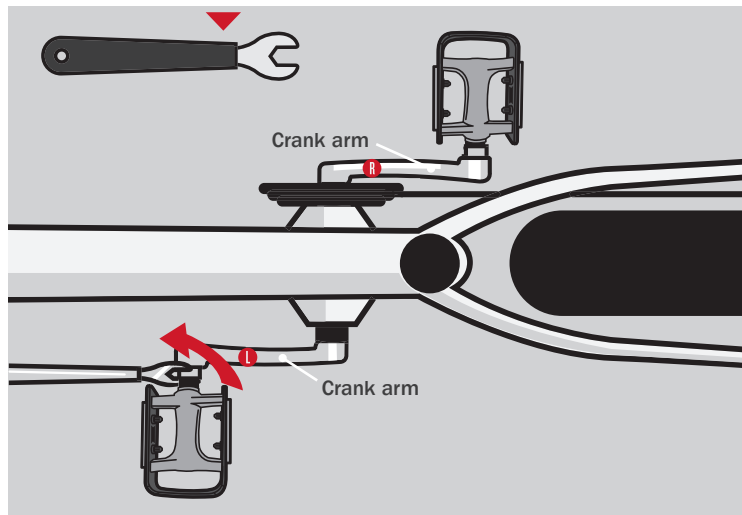
**7**

Install the seatpost into the seat tube.

**NOTICE:** Do not use grease on carbon frames or seat tubes. Standard grease can damage carbon.

1. Insert the seatpost into the seat tube.
2. Align the seat with the top tube.
3. Use the torque wrench to tighten the seatpost collar bolt until you feel the tool click.

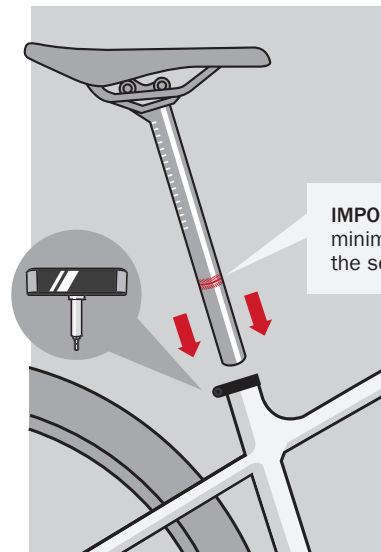

## Install the front wheel.

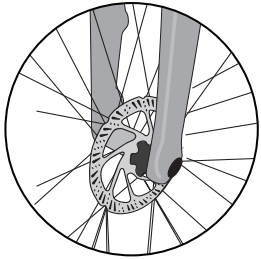

Disc brakes: Steps 8-9

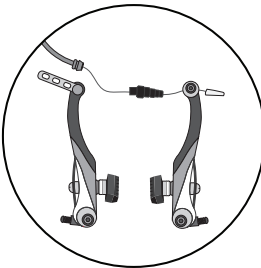

Rim brakes: Steps 10-11

## 8

### Disc brakes: Remove the fork mount and pad spacer.

1. Turn the lever counterclockwise to disconnect the axle. Pull the axle out of the fork mount.
2. Remove the fork mount.
3. Remove the pad spacer from between the brake pads.

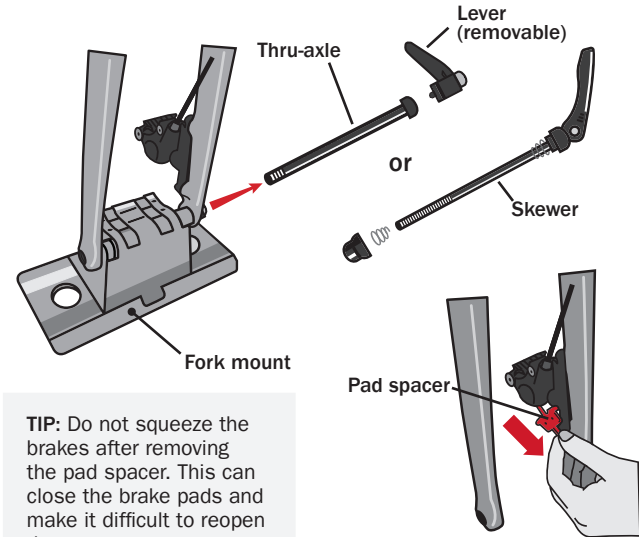

**TIP:** Do not squeeze the brakes after removing the pad spacer. This can close the brake pads and make it difficult to reopen them.

**9****Disc brakes: Install the front wheel.**

1. Lift the front of the bike, insert the rotor into the disc brake, and fit the hub into the fork.
2. Insert the axle into the hole in the fork and through the hub.
3. Turn the lever clockwise to thread the axle into the fork or nut. Hand tighten it securely to fully install the axle.

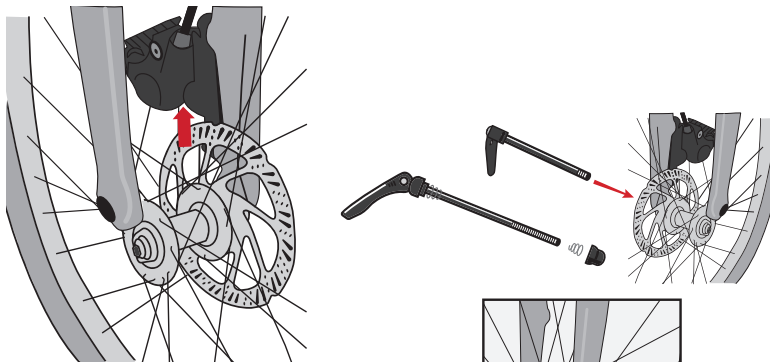

Go to Step 12

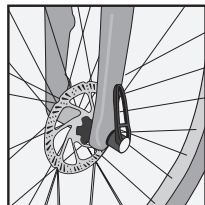
**12**

Locked position

**10****Rim brakes: Remove the fork mount.**

1. Open the lever and turn the nut counterclockwise to disconnect and remove the quick release axle (skewer, two springs, nut).
2. Remove the fork mount.

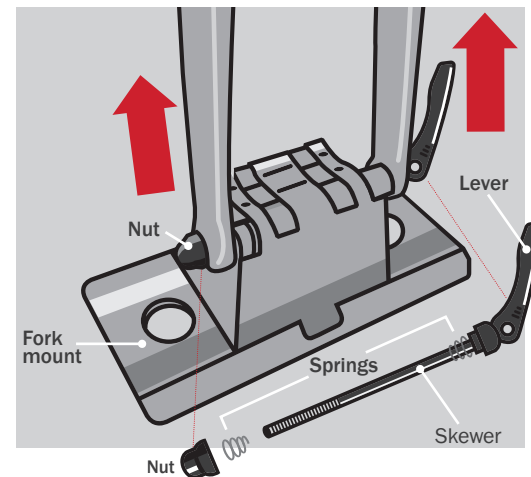





## Rim brakes: Install the front wheel.

1. Insert the skewer with a spring through the front wheel hub.
2. Put the other spring (small end first) on the skewer and screw on the nut three turns.
3. Lift the front of the bike and insert the front wheel axle into the spaces at the bottom of the fork. Set the bike down.
4. Make sure the quick release lever is on the same side as the quick release lever on the rear wheel.
5. Make sure the axle is fully seated in the fork.

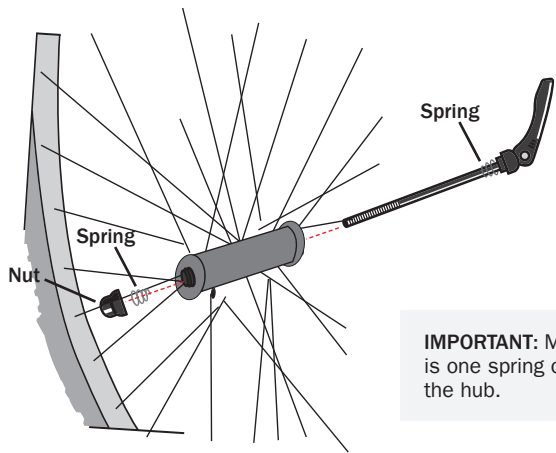

**IMPORTANT:** Make sure there is one spring on each side of the hub.



## Rim brakes: Install the front wheel (continued).

6. Facing the bike, place the front wheel between your legs. Start to tighten the nut with the quick release lever open. After you feel resistance in the lever, close the quick release lever towards the rear of the bike.
7. Squeeze the brake calipers and insert the cable stop into the arm linkage. Make sure the housing stop is properly seated in the arm linkage.

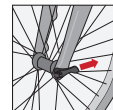
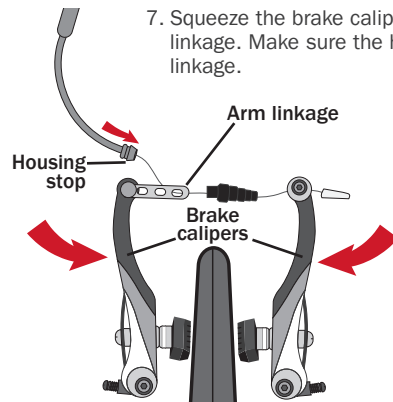

Lever faces rear of bike

### IMPORTANT:

1. The nut should be tightened enough that you need to wrap your fingers around the fork to close the lever.
2. The motion of the lever should have some resistance when it's about half way closed.
3. If the lever moves too easily, release the lever, tighten the nut, and try closing the lever again.
4. The lever should leave a clear imprint in your palm, and the nut should emboss the surface of the fork.

**⚠ WARNING:** Securely clamping the wheel with a quick release system takes considerable force. If the wheel is not properly secured, the wheel can become loose or fall off which may cause serious injury.

## 12 Inflate both tires.

1. Remove the dust cap.
2. Presta only — rotate the valve head counterclockwise to open it.
3. Inflate both tires to within the range listed on the tire.
4. Presta only — rotate the valve head clockwise to close it.
5. Put the dust cap back on the valve.

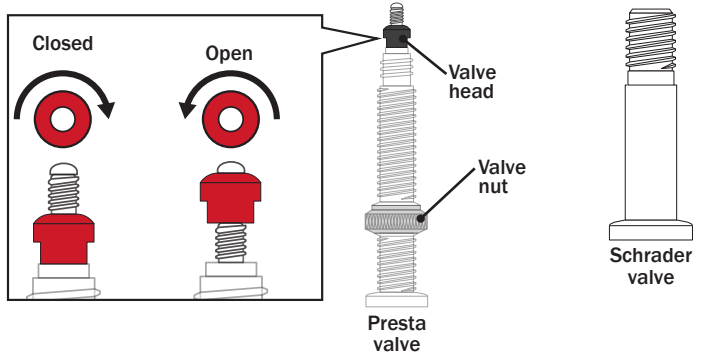
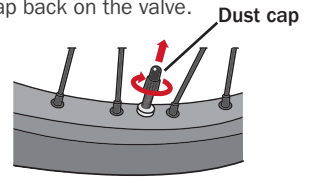

## 13 Adjust the seat height.

1. Put the bike next to a wall for support.
2. Sit on the seat to test the seat height. Your knee should be slightly bent when your foot is at the lowest position.
3. Adjust the height as necessary by raising or lowering the seatpost.

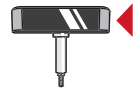

4. After determining your seatpost height, use the torque wrench to tighten the seatpost collar bolt until you feel the tool click.



# BICYCLE ASSEMBLY CHECKLIST

After you assemble your bike, complete this checklist:

- Handlebar and stem properly aligned? *(Step 3)*
- Faceplate bolts properly tightened? *(Step 4)*
- Pedals installed correctly and tightened? *(Steps 5-6)*
- Front wheel installed correctly? *(Step 9 or 11)*
- Tires inflated to correct pressure? *(Step 12)*
- Seat height correct and seatpost collar bolt tightened? *(Step 13)*
- Register your bicycle?
- Perform a pre-ride check?



Register your bike  
at [trekbikes.com/  
ProductRegistration](https://trekbikes.com/ProductRegistration)



Watch the Pre-Ride  
Check video at:  
[youtube.com/user/  
trebikesusa](https://youtube.com/user/trebikesusa)

**RIDE BIKES  
HAVE FUN  
FEEL GOOD**

For information about your bike's warranty, please see  
[trekbikes.com/inside\\_trek/warrantied\\_for\\_life](https://trekbikes.com/inside_trek/warrantied_for_life)



---

If you have questions, please contact your local Trek  
bike shop, call Trek Customer Care at 800-585-8735  
from 9am – 5:30pm Monday – Friday CST, or chat  
with us at [trekbikes.com/contactus](https://trekbikes.com/contactus)



**CERTIFIED AWESOME  
BY TREK**

PN 5317402